

No. 646,499.

Patented Apr. 3, 1900.

W. LODGE.  
LATHE REST.

(Application filed Nov. 6, 1899.)

(No Model.)

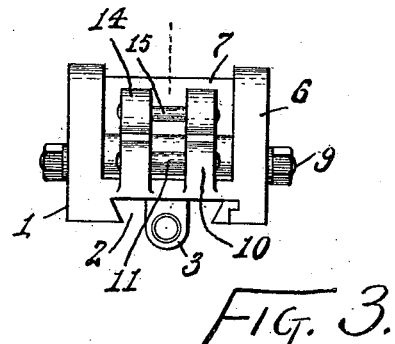
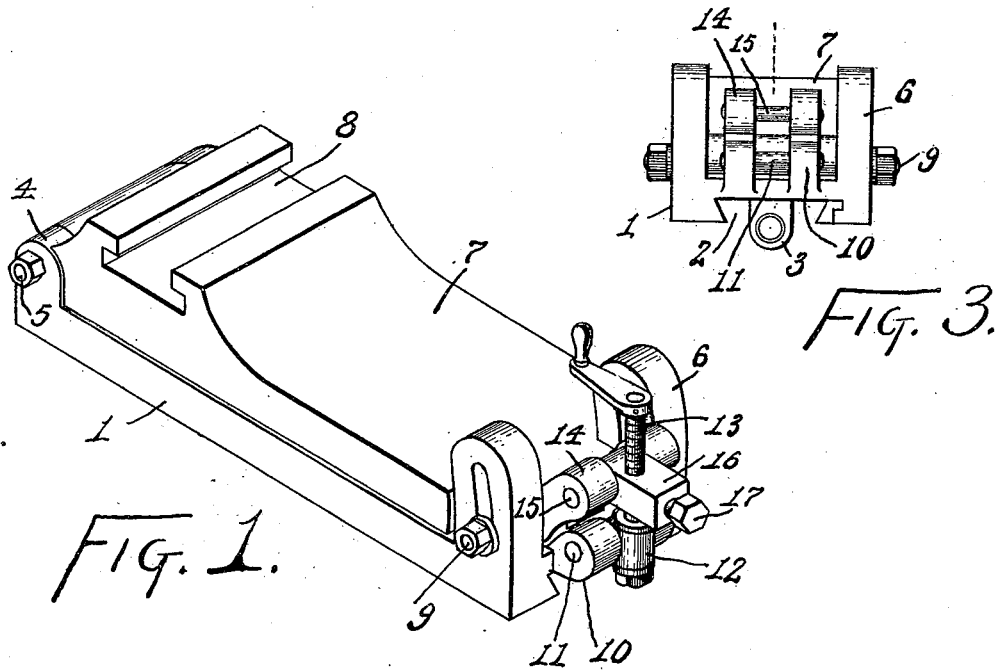
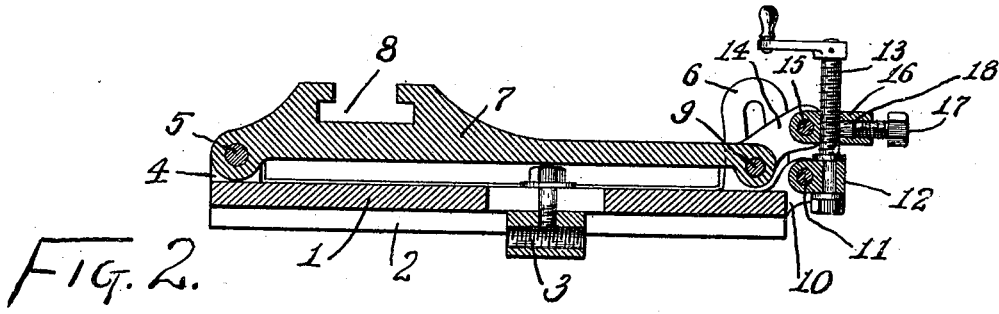

William Lodge

Witnesses:  
*E. R. Shipley*  
M. S. Beldew.

Inventor  
by James W. See  
Attorney

# UNITED STATES PATENT OFFICE.

WILLIAM LODGE, OF CINCINNATI, OHIO, ASSIGNOR TO THE LODGE & SHIPLEY  
MACHINE TOOL COMPANY, OF SAME PLACE.

## LATHE-REST.

SPECIFICATION forming part of Letters Patent No. 646,499, dated April 3, 1900.

Application filed November 6, 1899. Serial No. 735,923. (No model.)

*To all whom it may concern:*

Be it known that I, WILLIAM LODGE, of Cincinnati, Hamilton county, Ohio, (post-office address No. 3055 Colerain avenue, Cincinnati, Ohio,) have invented certain new and useful Improvements in Lathe-Rests, of which the following is a specification.

This invention pertains to lathe-rests and is designed to improve the working of elevating lathe-rests of the hinged type, so as to adapt them to heavy as well as light and ordinary work.

My invention will be readily understood from the following description, taken in connection with the accompanying drawings, in which—

Figure 1 is a perspective view of a lathe-rest embodying my invention; Fig. 2, a vertical longitudinal section of the same, and Fig. 3 a rear elevation of the same with the elevating-screw and its immediate adjuncts omitted.

In the drawings, 1 indicates the base of the rest, designed to slide across an ordinary lathe-carriage in the usual manner; 2, a dovetail groove in the under surface of the base, adapted to engage the usual dovetail rib upon the lathe-carriage, it being understood, however, that such engagement of the rest with the lathe-carriage is of exemplifying character only and that whatever may be the form of the lathe-carriage with which the improved rest is to be employed the base of the rest will be adapted to fit it, so as to slide across it in the usual manner; 3, the usual cross-feed nut secured to the base of the rest, the exemplification showing this nut as held to the base by a screw engaging a longitudinal slot in the base, a not unusual arrangement where a lathe-rest is employed in connection with a taper attachment; 4, a pair of lugs projecting upwardly from the front corners of the base, it being understood that the left-hand end of the rest as it appears in Fig. 2 may be considered as the front end or end nearest the lathe-carriage; 5, a horizontal hinge-pin mounted in the lugs 4 and extending across above the front end of the base; 6, a pair of lugs projecting upwardly from the rear corners of the base and provided with segmental slots whose arcs center at hinge-pin 5; 7, the

top rest, disposed over the base and having its front end hinged on hinge-pin 5 and having its rear end engaging snugly between lugs 6; 8, the tool-post slot, extending across the top rest and having an ordinary form and being merely exemplifying of tool-holding provision for the lathe-rest; 9, a bolt extending horizontally across the rest through the segmental slots in lugs 6 and through the rear end of top rest 7 and provided, at one end at least, with a nut and washer, by means of which it may be tightened, the illustration showing the bolt as being provided with a nut and washer upon each end, so as to permit the tightening to be done at either end of the bolt; 10, a pair of ears projecting from the rear end of base 1; 11, a horizontal pin mounted in these ears and extending across the space between the ears; 12, a bearing-block mounted on pin 11 between the ears 10 and having a vertical bearing for the journal of the elevating-screw, the axis of this vertical bearing being rearward, but close to pin 11; 13, the elevating-screw, with its foot journaled in the vertical bearing of block 12, in which it may turn, but not move endwise; 14, a pair of ears projecting rearwardly from top rest 7 over the ears 10 of the base; 15, a horizontal pin mounted in the ears 14 and extending across the space between the ears; 16, a nut-block mounted on pin 15 between the ears 14 and having rearward of pin 15 a threaded hole engaging the thread of the elevating-screw; 17, a set-screw threaded into the rear portion of nut-block 16 and adapted to screw toward the elevating-screw, and 18 a plug interposed between the body of the elevating-screw and the end of set-screw 17.

In ordinary use the improved rest may be viewed as a simple solid lathe-rest or tool-block sliding on the carriage, hinge-pin 5 and bolt 9 binding the top rest and base firmly together, so as to give the structure the firmness and stability of a solid rest; but by slacking bolt 9 and manipulating the elevating-screw the top rest, and consequently the tool carried by it, may be vertically adjusted, the parts swinging on hinge-pin 5 as a center. After the vertical adjustment has been properly made bolt 9 may be again tightened, thus again giving the rest the qualities

of a solid rest, with the tool in new position of vertical adjustment. It is thus seen that the rest, while having the qualities of an elevating rest, has also all of the qualities of a solid rest, adapting it to the heaviest class of lathework. For medium hard work the bolt 9 may be slackened a trifle, thus permitting the ready vertical adjustment of the tool at all times, the structure being then at all times firm enough for such character of work. For ordinary light work in turning bolt 9 may be left quite slack, sufficient stability being given the top rest by the elevating-screw in conjunction with the fit of the top rest upon the base, the strain of the turning-tool being downward and the strain being met by the elevating-screw and the hinge-pin. When the rest is used with a boring-tool having extended outreach, a peculiar strain is brought upon the rest, and it is in connection with such work that elevating rests of the hinged type have generally developed serious and often fatal weakness. In the improved rest the bolt 9 may be tightened and the rest rendered as stable as a solid rest.

Hinge-pin 5 will preferably have a taper fit in the top rest, after the manner in which the tool-apron of a planer is usually fitted, so that a nice snug fit may be produced and maintained. The elevating-screw is obviously given a tipping motion as the top rest rises and falls, the swiveling of blocks 12 and 16 upon their pins readily permitting this motion. When the rest is employed on light work, with bolt 9 slack, an extra steadying duty is imposed upon the elevating-screw,

and in such case the effect of lost motion in the elevating-screw may be nullified by means of set-screw 17 clamping the elevating-screw firmly to its nut-block 16, plug 18, preferably of brass, preventing the set-screw marring the threads of the elevating-screw.

I claim as my invention—

1. In a lathe-rest, the combination, substantially as set forth, of a base adapted to slide upon the lathe-carriage, a top rest disposed above the base and adapted to support a tool, a hinge-pin uniting the front end of the top rest to the base, a horizontal binding-bolt uniting the rear end of the top rest to the base, and means for vertically adjusting the rear end of the top rest relative to the base.

2. In a lathe-rest, the combination, substantially as set forth, of a base adapted to slide upon the lathe-carriage, a top rest disposed above the base and adapted to support a tool, a hinge-pin uniting the front end of the top rest to the base, ears projecting from the rear end of the base, a pivot-pin supported thereby, a bearing-block mounted on said pivot-pin, an elevating-screw journaled in said bearing-block to the rear of said pivot-pin, ears projecting from the rear of the top rest, a pivot-pin carried by said last-mentioned ears, and a nut-block mounted on said last-mentioned pivot-pin to the rear thereof and engaging said elevating-screw.

WILLIAM LODGE.

Witnesses:

MURRAY SHIPLEY, Jr.,  
LOUIS B. WEBER.